



VÄT GAS SVERIGE

HYDROGEN SWEDEN CONFERENCE 2018

Funderingar



SÄKERHET

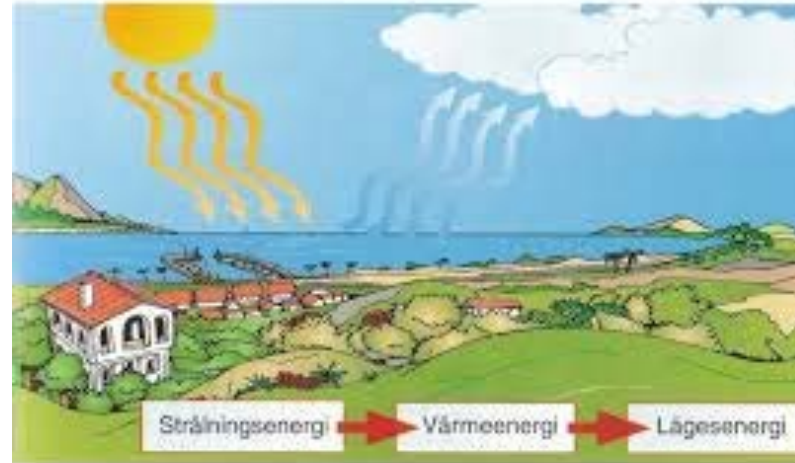

Strålningsenergi kan bli lägesenergi.

EFFEKTIVITET



KOSTNADER

Hur fungerar en bränslecell?

1. Vätgas (H_2) och syre (O) ur luften leds in i bränslecellen
2. Vätgasens elektroner kan inte ta sig igenom bränslecellen utan tar sig via t.ex. en lampa till andra sidan
3. Vätgasens protoner tar sig dock rakt igenom och reagerar med luftens syre
4. Elektricitet, vatten (H_2O) och värme är enda utsläpp

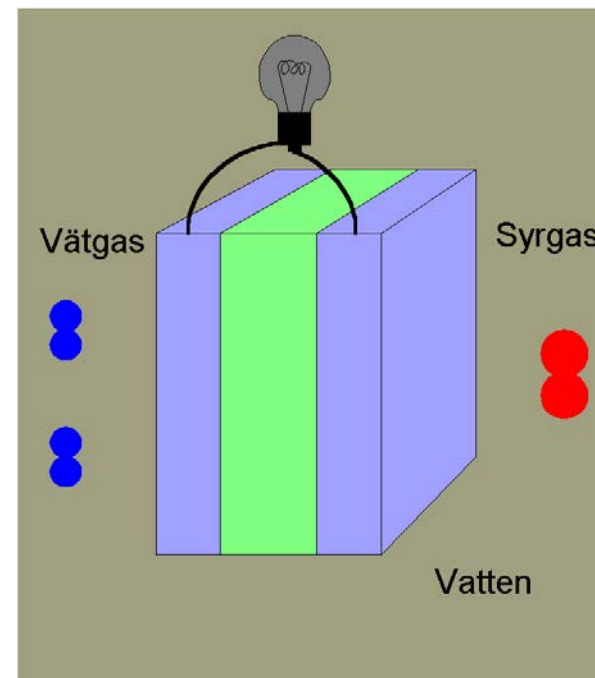

Bränsleceller

- PEM (lågtemp.)
- SOFC (högtemp.)

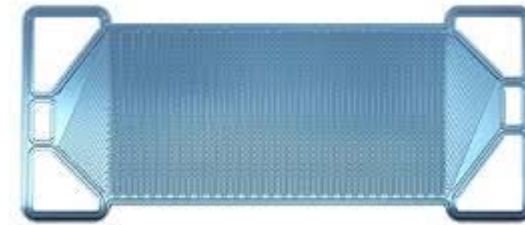

Bränsleceller

UTMANINGAR

- Kostnad – volym, automatisering, (livslängd)
- Platina – reducering, återvinning, annan katalysator

Elektrolysörer

- PEM – dyrare, snabba
- Alkaliska – billigare, långsammare



På insidan...

- Globala standards
- 3-4 min tankning
- 45-80 mil

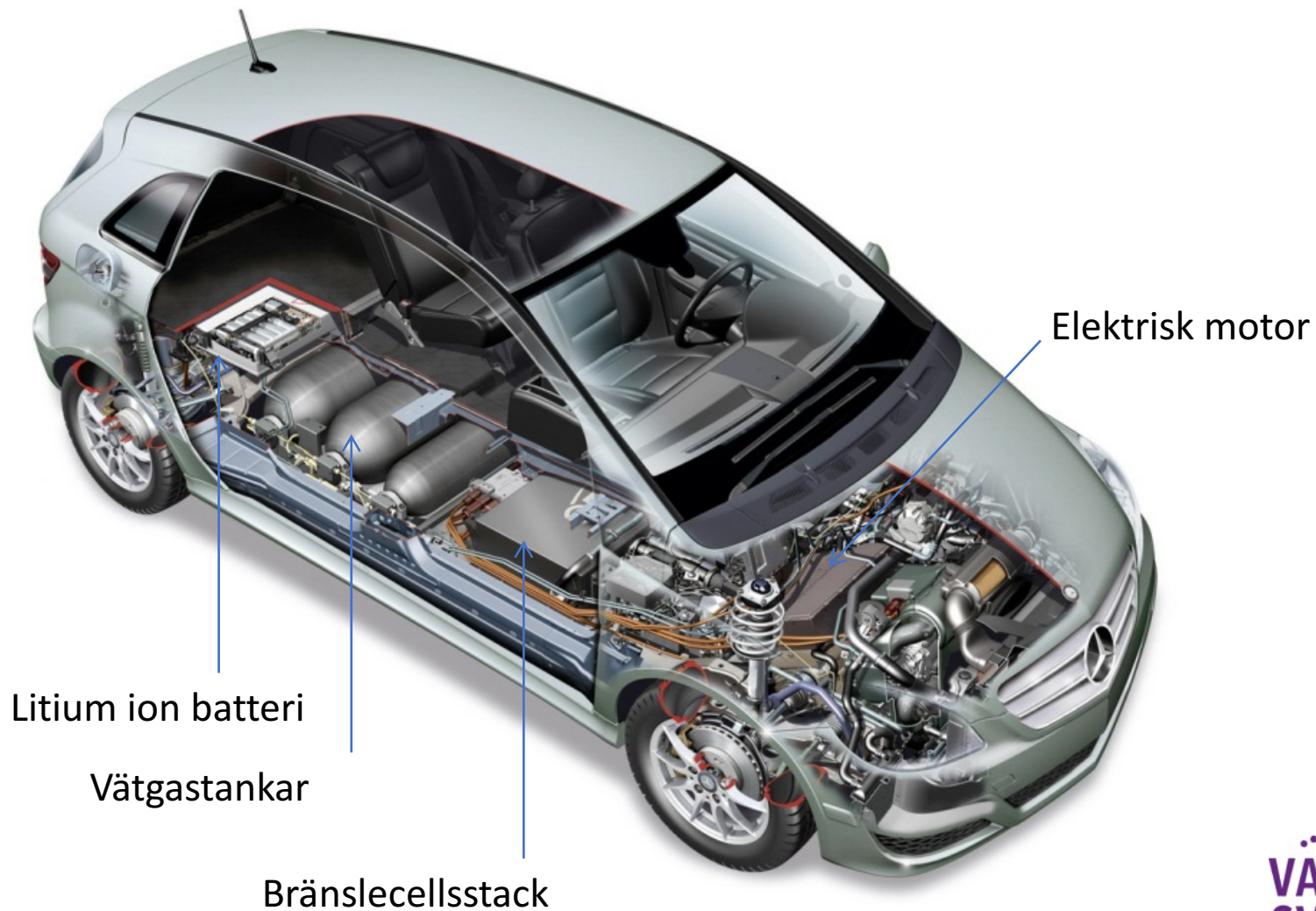

SAMARBETEN OCH LANSERING OEM:S



VÄTGAS
SVERIGE

Nya bränslecellsfordon 2018



HYUNDAI NEXO



MERCEDES GLC F-CELL

Tunga bränslecellsfordon





- Globala standards
- 350/700 bar
- 3-5 min tankningstid
- 45-80 mil räckvidd
- Kapacitet 20-400 kg/dygn
- Pris: från 3-12 MSEK



- Footprint:
 - Endast dispenser 53x53 cm
 - 7 kvm uppdelad dispensererenhet
 - 40 fotscontainer - komplett enhet
- 50 kWh => 1 kg H₂ => 10 mil

Europa 2030

- DAFI: 14 länder
- 850 stationer till 2025

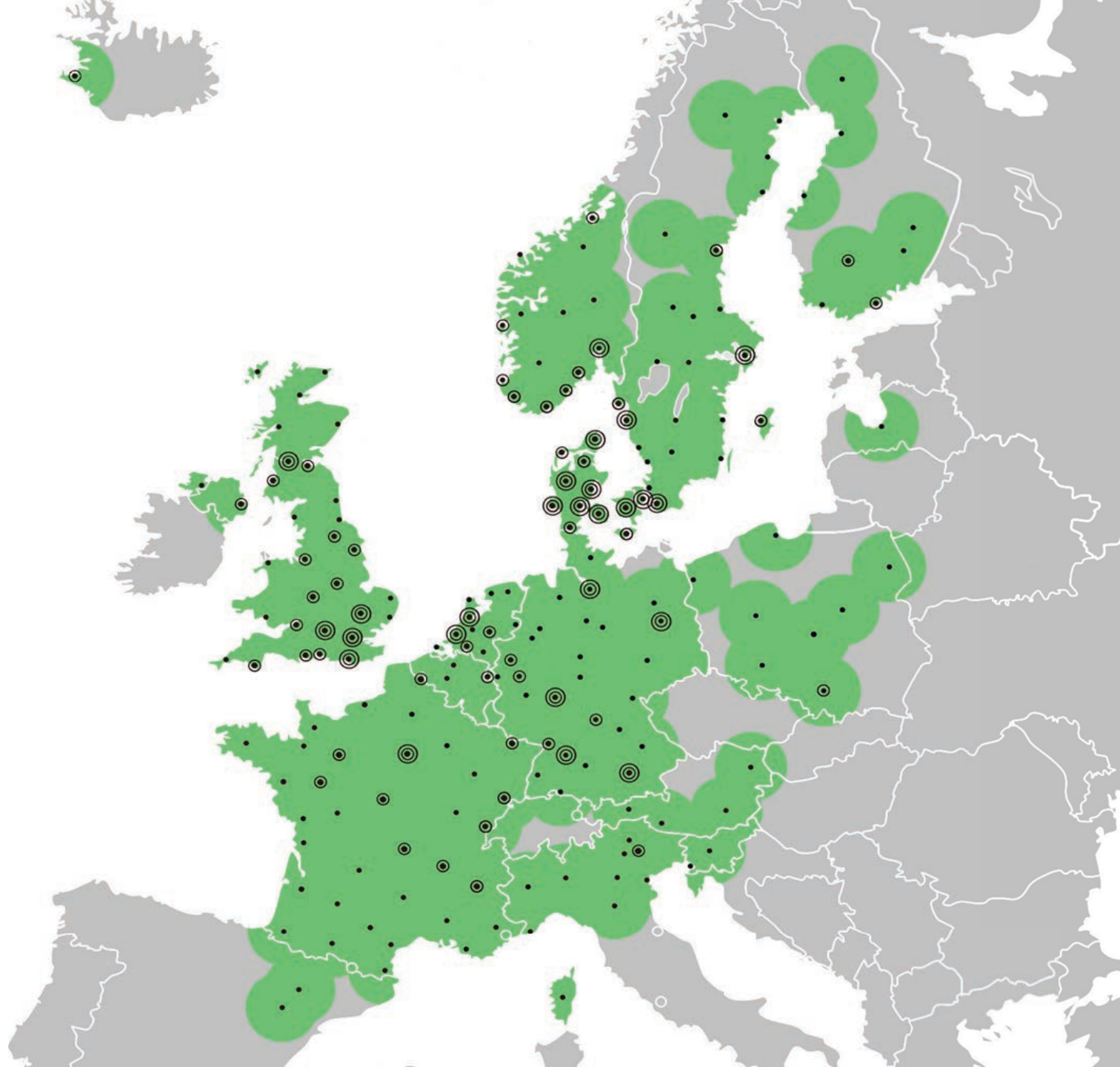

Initial plan for Sweden

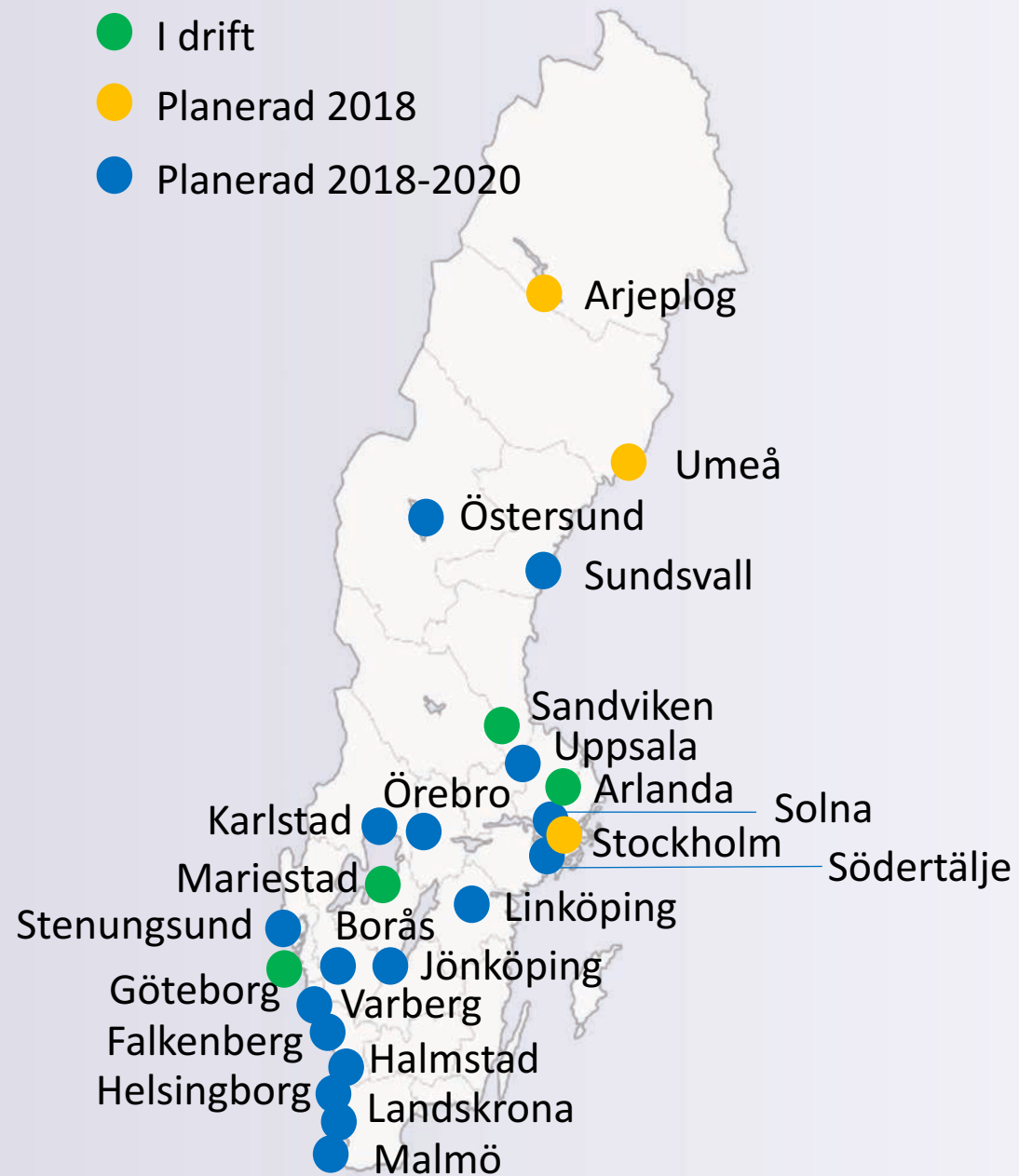

Status Sverige

HÅRDVARA

- > 40 bränslecellsbilar (FCEVs)
- 4 tankstationer (HRS)
- 5 bränslecellsbussar i JIVE2
- Nordic Hydrogen Corridor (NHC): +100 FCEVs, 8 HRS, 1 elektrolysör
- > 4 husprojekt med vätgaslagring

Status Sverige

STYRMEDEL, INITIATIV OCH POLITIK

- Bonus-malus
- Hybrit
- BSRHN
- NOTS
- 6 av 8 partier lovade öronmärkta pengar till vätgasinfrastruktur

Central

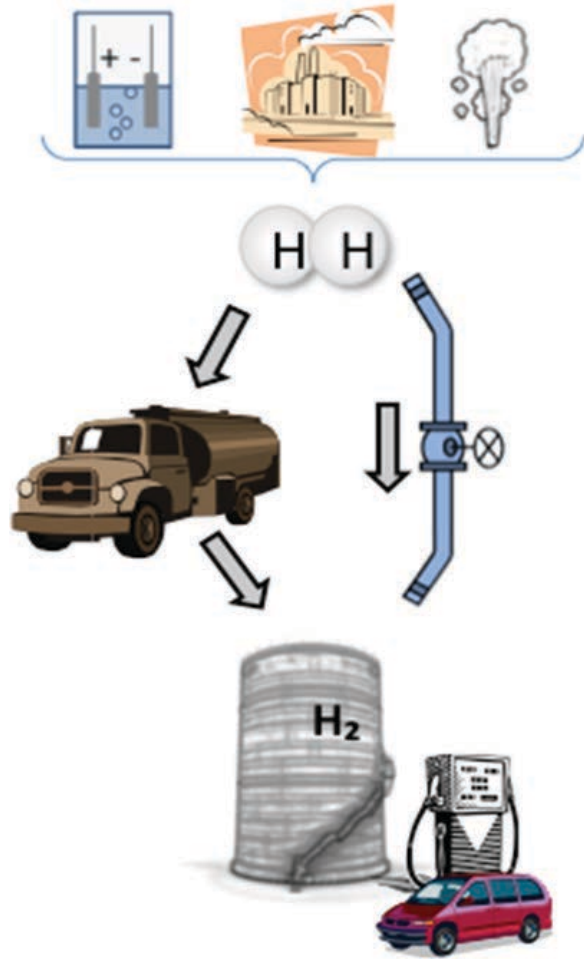

Decentralized

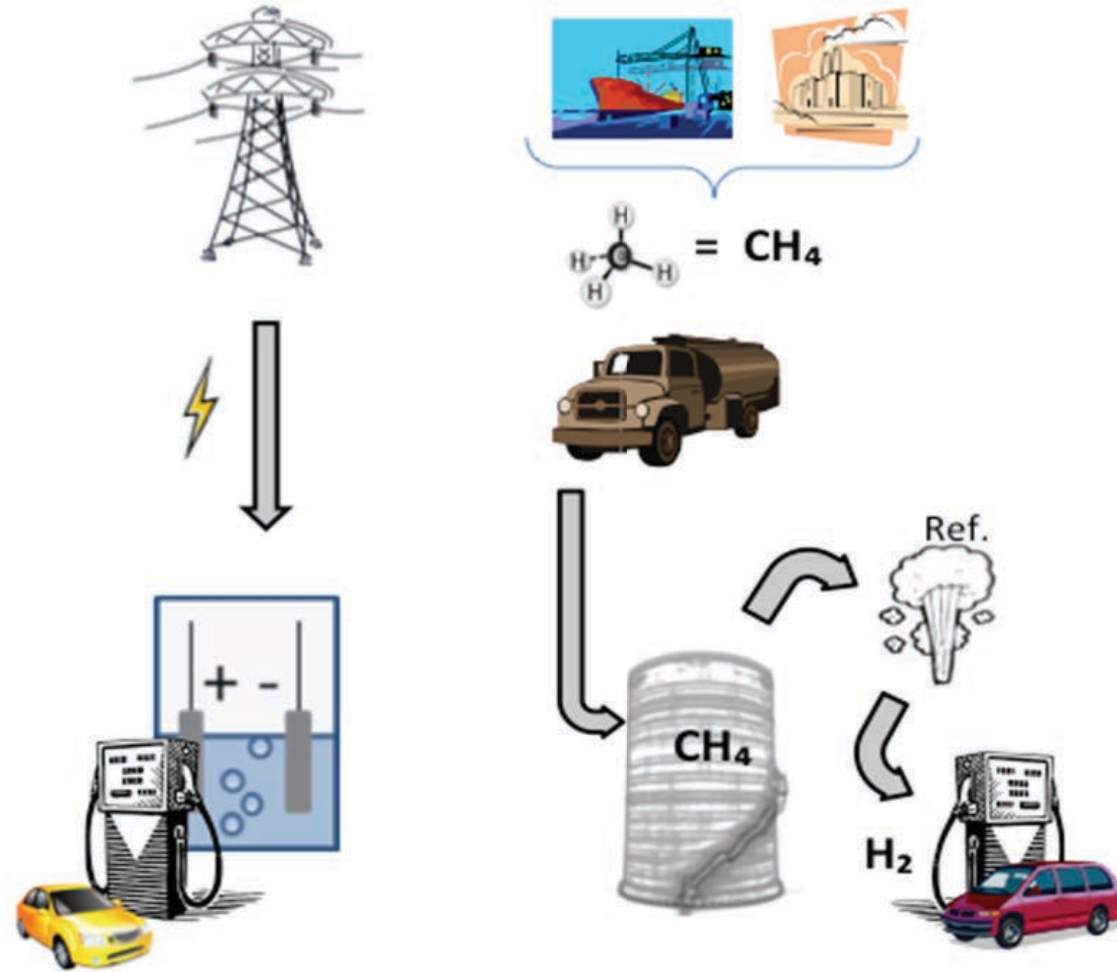

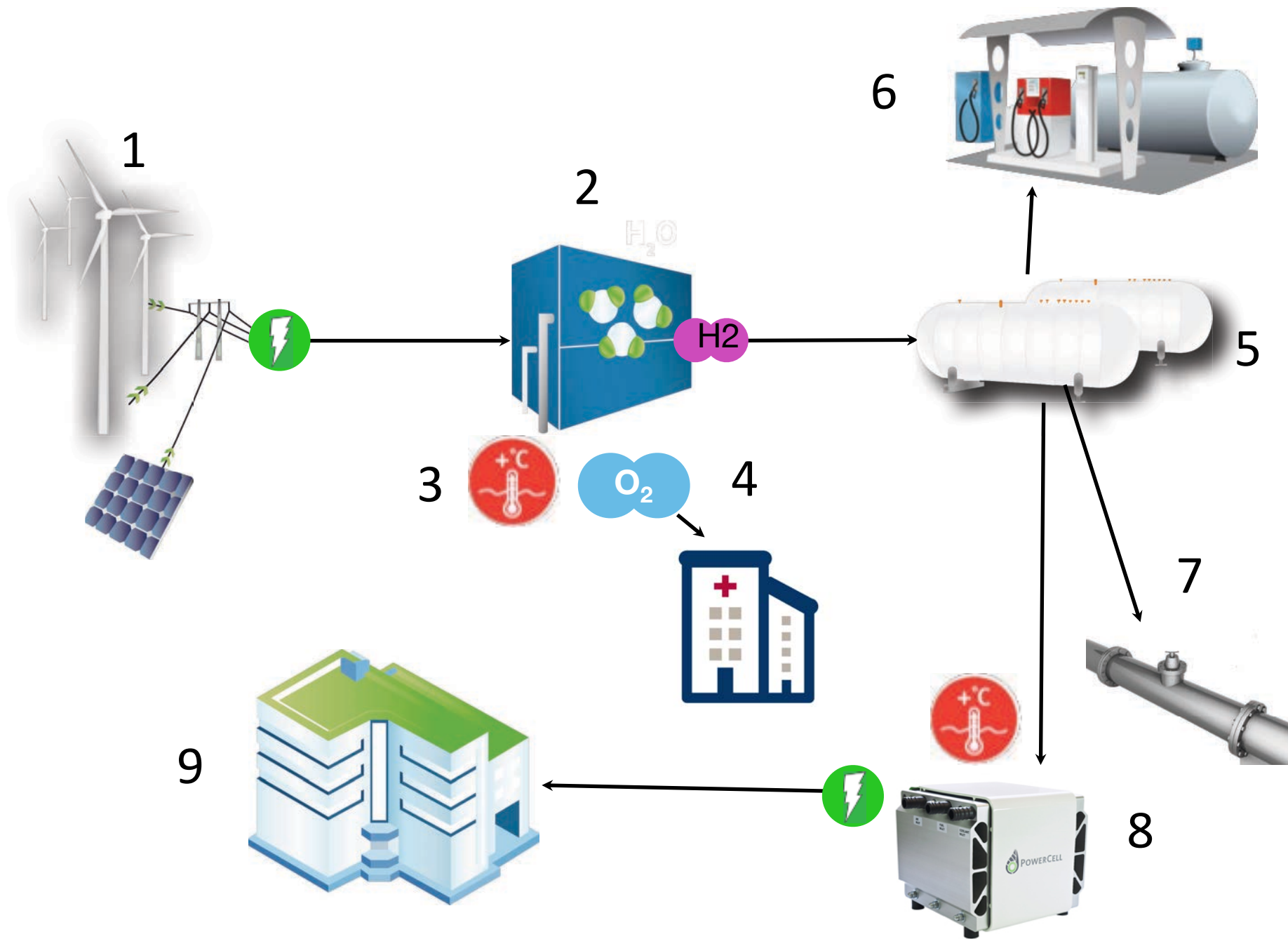

SMART HOME /OFF-GRID

Powered by solar energy and fuel cells using stored hydrogen

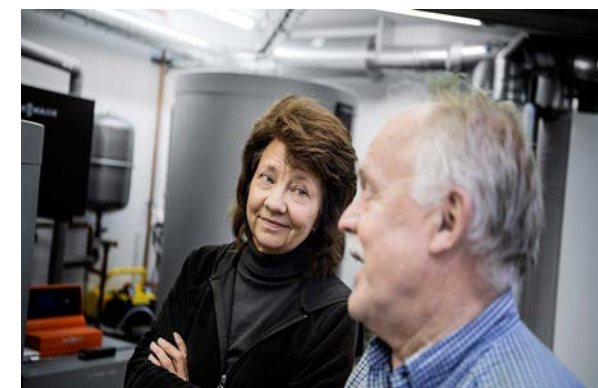
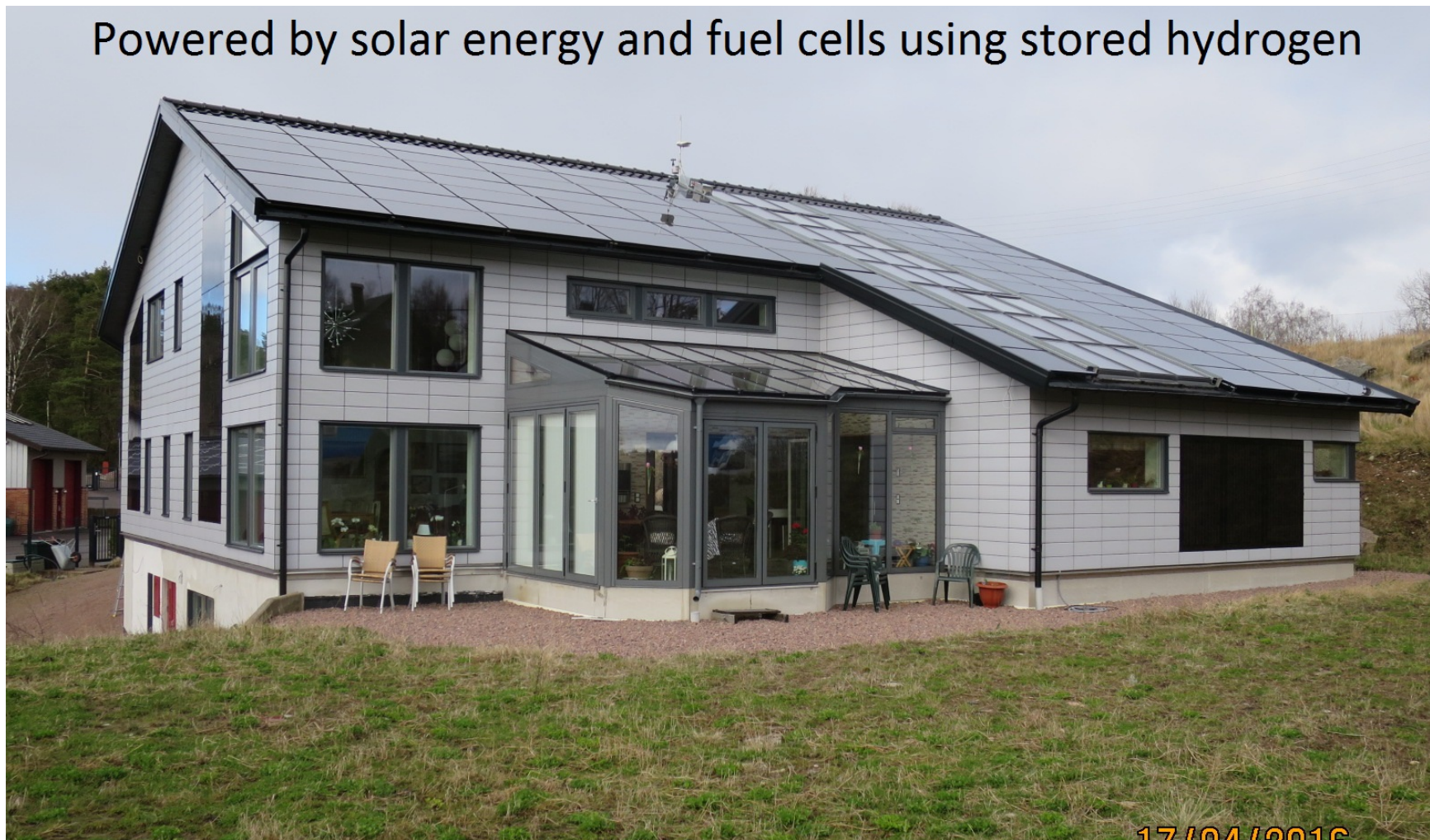

ENERGY SYSTEM SOLUTION

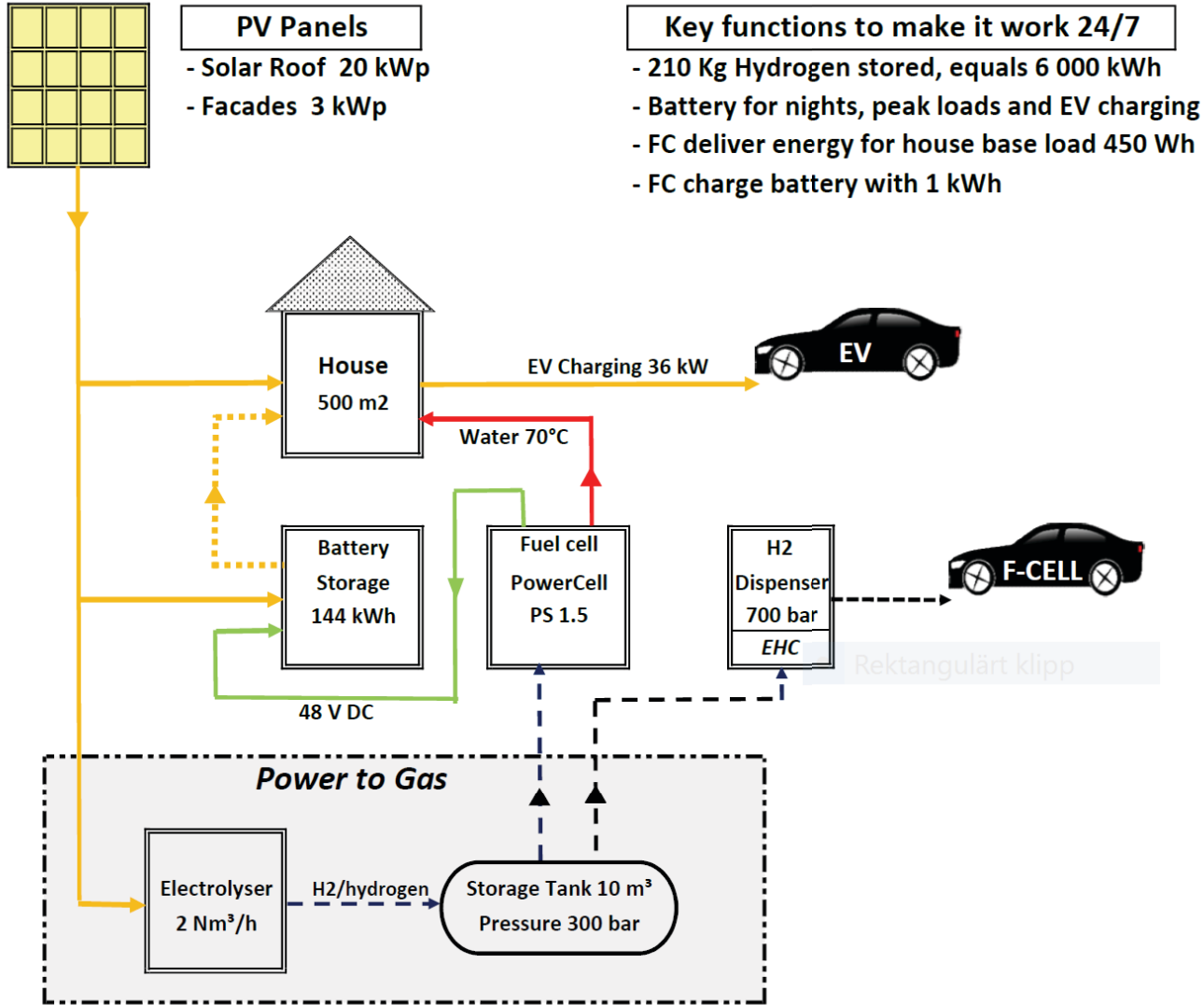

Potential med vätgas



EU2030:
13 miljoner
hushåll använder
vätgas och
850 000 nya
jobb skapas

TRL-nivåer i Sverige



TRL	H ₂ Produktion	Distribution	H ₂ lagring	Säkerhet	Bränsle-celler	Utrustning	Stationära bränsleceller	BC i maskiner	BC i fordon
1									
2									
3									
4									
5									
6									
7									
8									
9									

Drivkrafter!

LUFTKVALITET

- Fossiloberoende – fossilfritt – emissionsfritt
- Stort driv i Norge, Japan och Kalifornien
- Sverige ligger 2 ggr över 2-gradersmålet

EKONOMI

- Pengarna finns men hur väljer vi att använda dem?

ENERGILAGRING

- Möjliggör förnybar energi
- Försörjningstrygghet

Drivkrafter!

SYSSELSÄTTNING

- Nya utbildningar behövs
- Systemutvecklingskompetensen
- Forskningen – inget program efter Mistra (slut 2010)
- Exportpotentialen
- Vilken del av värdekedjan vill vi ha?
De som går före väljer och följarna får ta det som blir kvar.

NYTTAN

- Från verkningsgrad till "arbetsnytta"
- "Förlusterna" är biprodukter med värde: värme, vatten, syre

MEMBERS AND PARTNERS

HYDROGEN & FUEL CELLS



TRANSPORT



ENERGY



ENGINEERING



RESEARCH



PUBLIC ORG.



OTHERS



A photograph of two young women sitting at a table in a cafe, studying. The woman in the foreground is wearing an orange sweater and is looking at an open book. The woman behind her is wearing a blue and white striped shirt and is also looking at the book. There are coffee cups on the table. The background is slightly blurred, showing a dark leather booth and a lamp.

VÄTGAS SVERIGE

TACK!

BJÖRN ARONSSON, Verksamhetsledare

bjorn.aronsson@vatgas.se